



## SCION™ GC Series

- The Gas Chromatographers Choice for Separations

# Innovation in Gas Chromatography

Scion Instrument's long tradition of innovation and product reliability have combined to create the next generation of Scion Gas Chromatographs. By understanding and then designing to exceed the most critical performance and reliability needs of GC users, Scion Instruments is delivering systems that are especially for, and all about, the ultimate success of the GC user. The new SCION 436-GC and SCION 456-GC have been designed to meet the most important user specified requirements – reliable performance, ease of use and simple maintenance.

## Local User Interface

This large, high resolution display makes all GC functions accessible via touch screen control and "instant access" buttons. Easy to navigate and adapt it comes available in 13 languages for ease of local training and support.

## Fast, Flexible Detection

Scion Instrument's comprehensive range of detectors deliver industry leading sensitivity, ease of operation and outstanding reliability. And, now all Scion detectors feature fast sampling data rate (600Hz) for rapid separations and greater analysis throughput.

## Multi-language capability

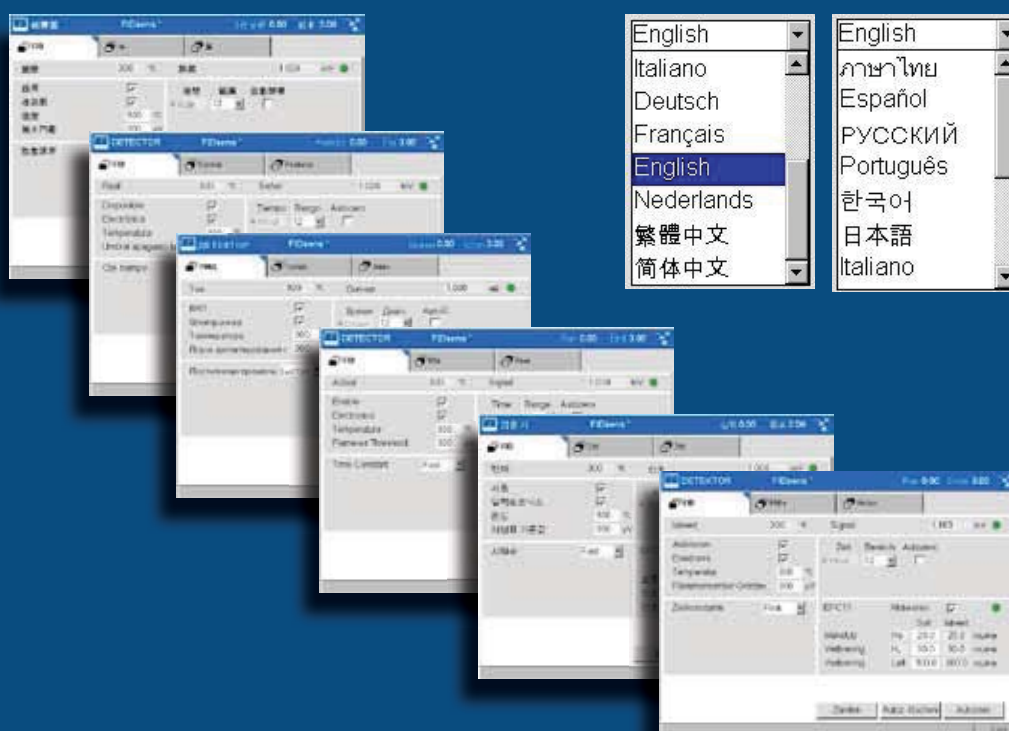

## SCION 436-GC

### Choice of multi inlet systems

- 2 injectors from 5 available
- Gas Sampling Valve
- Liquid Sampling Valve

### Choice of 7 GC traditional detectors

- Universal
- Specific

### MS detector

- Single Quadrupole (MS)



## SCION 456-GC

### Choice of multi inlet systems

- 3 injectors from 5 available
- Gas Sampling Valve
- Liquid Sampling Valve

### Choice of 7 GC traditional detectors

- Universal
- Specific

### MS detector

- Single Quadrupole (MS)



# Enhanced Operator Benefits

Scion Instruments offers a range SCION GCs to meet virtually all application requirements. All SCION GCs are equipped with the convenience of advanced EFC. Whatever the requirement, we have the solution.

## GC Control From Anywhere

The unique embedded control architecture incorporated into the GC enables the use of remote user interface software. This offers the user the ability to control the GC in the exact same way and with the same level of functionality as if they were standing at the GC using the User Interface but from a remote location, even from home.

## Gas Saving Capability

Essential to any laboratory is the requirement for cost control. Gas consumption is a major source of operational cost and reduction in gas flow when not necessary is a vital function of any modern GC. Scion GCs have the necessary functionality to save valuable gas and thus costs.

## Turnkey Analyzer Solutions

Scion Instruments configures and tests GC hardware and software according to widely used industry standard methods (e.g. ASTM, UOP, EN, ISO, GPA), to save its clients time and to ensure confidence in results. Standard analyzers are configured to meet the performance specifications outlined in the method itself. Included in these analyzer packages:

- All hardware
- Software (including special application "plug-ins" when appropriate)
- Pre-installed methods
- Test chromatograms
- Installation/validation data
- User documentation customized to the specific method

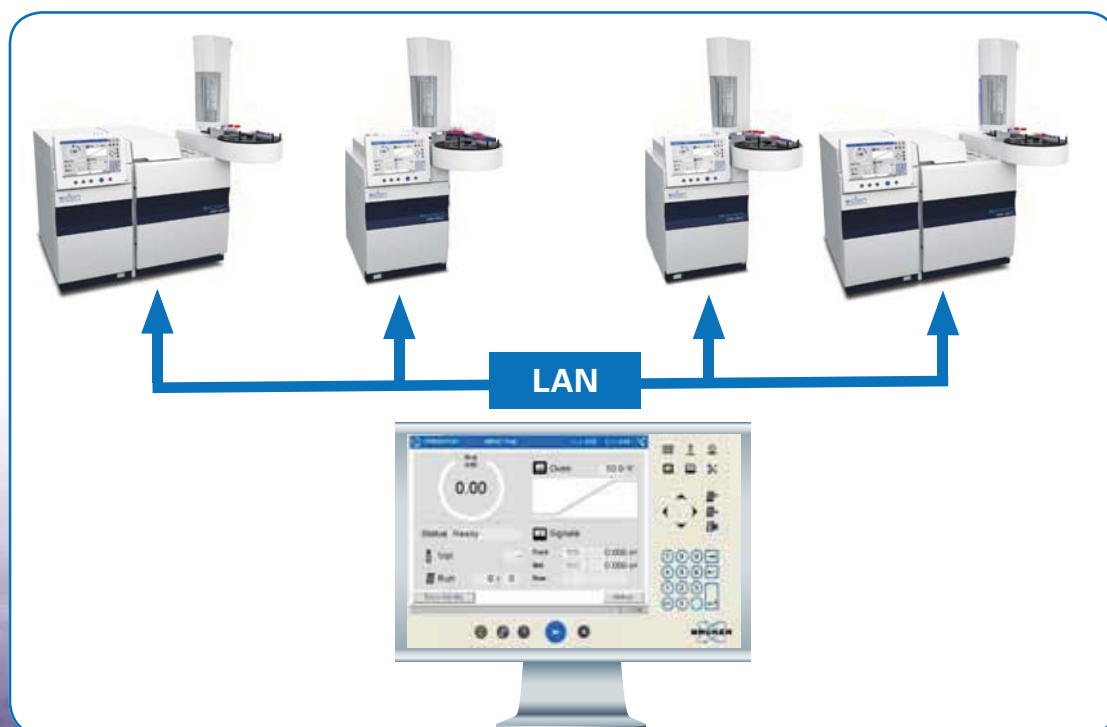

### Targeted Solutions for Specific Markets

A series of software customization tools allow users to develop unique calculation modules, that fully integrate with compassCDS. A large number of standard plug-ins are available that allow special reporting and other post analysis functions. Some examples include:

#### Simulated Distillation

Provides automated boiling point distributions for a full range of petroleum products for applications that comply with ASTM, IP, DIN and ISO standard test methods.

#### Detailed Hydrocarbon Analysis

Reports in an automated way the physical properties of gasoline and similar products based on individual components for applications that comply with Bruker developed methods and ASTM, IP and standard test methods.

#### CompassCDS PeakSynch

Provides rapid visual and quantitative comparison of complex chromatograms and is widely used in the flavor and fragrance industry.

#### Simulated Distillation

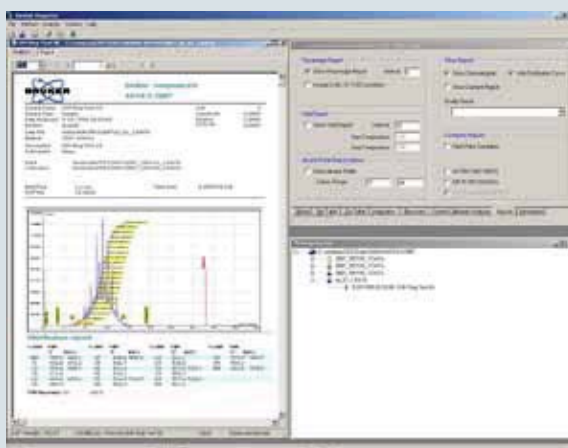

#### CompassCDS PeakSynch

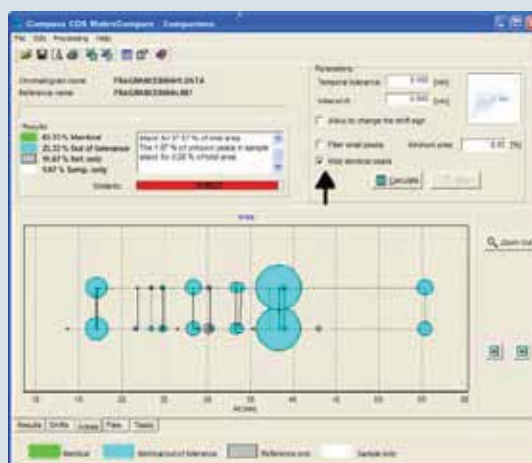



scion  
INSTRUMENTS

scion 50  
455-SC



## Benefits of the SCION-GC

- Multi-language User Interface
- Full EFC Capability
- High Pressure Injection
- IntelliUpdate
- System Suitability Determination
- compassCDS software
- 600 Hz Data Sampling Rate On All Detectors
- Inert GC Sample Path
- Constant Linear Velocity Mode
- Fast Cycle Time

### SCION 436-GC



- Small foot print
- High performance
- Dual channel architecture

### SCION 456-GC



- Solutions platform
- Total flexibility
- Four channel architecture

# Increased Productivity

With over 40 years' experience in gas chromatography, we can provide unrivalled expertise, not only in building robust instruments, but also in creating solutions for ensuring productivity. With total control over design and manufacturing, Scion Instruments ensures the quality and technological excellence of its products is complimented and combined with features that deliver the true benefits of productivity.

## Speed increased with a factor 6.5

- Small ID from 0.25 to 0.1mm
- Short column from 15 to 4 mtr
- Increased ramp from 10 to 65 °C/min
- Data rate from 25 to 200 Hz

## Fast Cycle Time

The time between injections can considerably improve productivity. The high performance oven incorporating design characteristics that enhances fast heating and cooling ensures maximum productivity. This, in conjunction with high pressure injectors and ultra narrow bore columns will significantly improve and yield fast cycle times without loss of performance (see chromatograms).

## IntelliUpdate

In many cases instrument and system effects (column ageing, matrix, etc.) can cause experimental deviations e.g. retention time. compassCDS IntelliUpdate function can be used automatically to correct and compensate for such deviations. This unique capability is also done without changing fundamental instrument parameters, maintaining accuracy of results and method continuity.

A) Methane peak eluting at 5.00 minutes automatically identified with associated Halve Peak Width timed event at 4.96 minutes. B) Methane peak eluting 0.1 minutes later due to column deterioration over time with peak no longer identified and timed event missed as software has not compensated. C) IntelliUpdate feature automatically updates peak Retention Time and timed event tables after each run to compensate for peak and timed event migration.

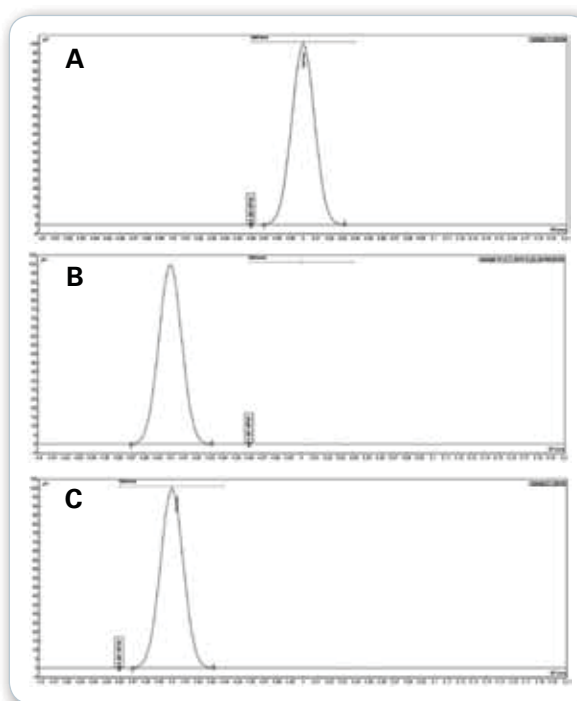
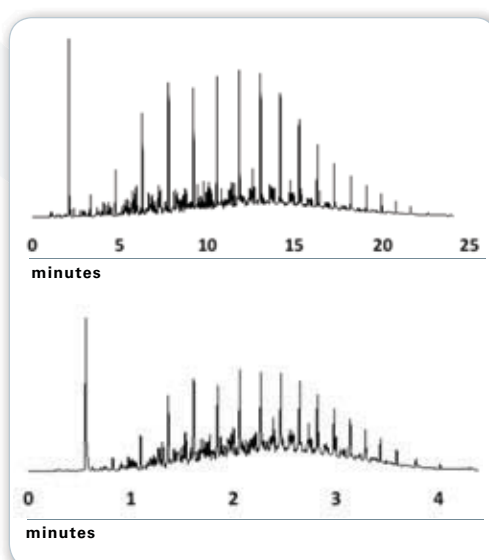



### Optimized Switching Valves

Flow splitting, backflushing and Deans switching are valuable techniques in improving cycle times, analytical performance and the robustness of GC methods. Splitting the flow of column effluent into differing detectors can enhance performance, quantitation and confirmation of targeted compounds.

Backflushing is key to reducing analysis time and column protection. It works on the basis of reversing column flow after peaks of interest have been detected. This eliminates the need for time and temperature segments to elute highly retained components injected with compounds of interest. Reversing the flow elutes these materials out through the split vent of the injector with the added benefit of protecting the column from degradation and contamination.

Backflushing capability also allows column changes and injector maintenance without loss of vacuum in the MS detector.

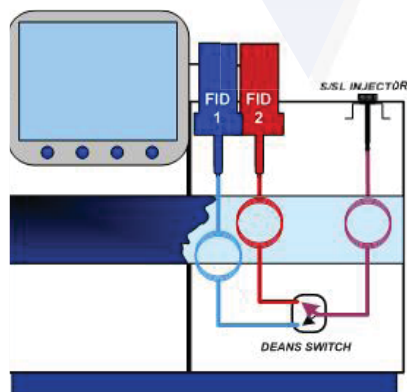
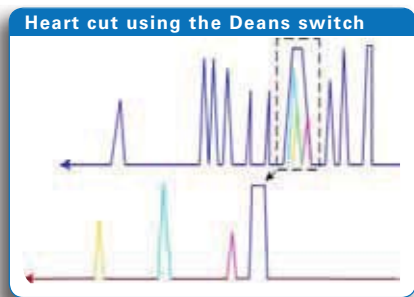
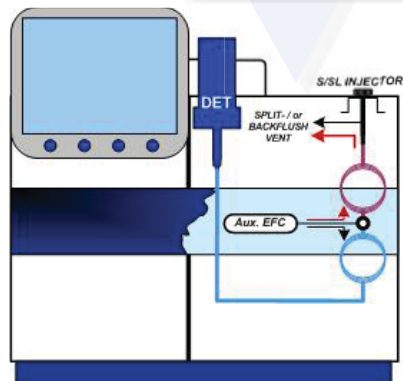
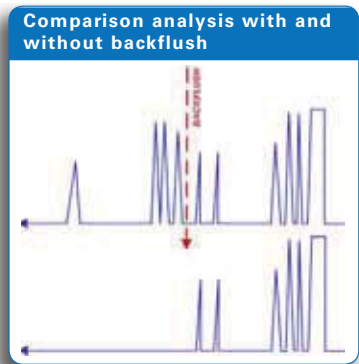

Deans switching enables the use of multiple traps and columns of differing phases in one method/analysis. It is the basis of two dimensional GC and many standard analyzers manufactured by Scion Instruments. Use our expertise to configure the optimum system for you.

# Capability and Automation

Scion Instruments offers an injector and detector range to meet virtually all application and market requirements. All are equipped with the convenience of advanced EFC. Whatever the requirement, be it Split/splitless, Cold-on-Column, Packed, Flash or Programmable Temperature Vapourizing injector with a universal or specific detector we have the solution.

	Universal				Specific		
	FID	TCD	PHHID	MS	ECD	NPD (TSD)	PFPD
 Academic	✓	✓		✓		✓	
 Environment			✓	✓	✓	✓	✓
 Food Beverage	✓		✓	✓	✓	✓	✓
 Forensics Toxicology	✓			✓			✓
 Petroleum	✓	✓	✓	✓	✓	✓	✓

Scion Instruments offers a range of differing injector designs for all applications, column dimensions and can be fully automated.

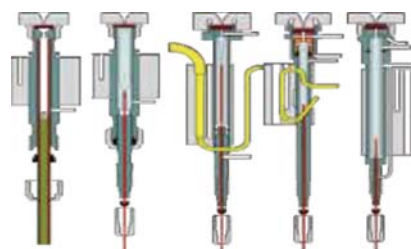

## Injector Selection Guide - Sample/Analysis Characteristics or Requirements

Trace Analysis	Separation & Speed	Sample Capacity	Wide Range of Analytes	Preferred Column Type	1st Choice	2nd Choice
✓				Capillary, 0.53 mm ID	Large Volume (LV)	Split/Splitless
	✓			Capillary, 0.1 to 0.53 mm ID	Split/Splitless	Large Volume (LV) SS Mode
	✓	✓		Capillary, 0.53 mm ID	Large Volume (LV)	
	✓			Capillary, retention gap	Cold On-Column	Large Volume PTV Mode
	✓			Capillary, 0.53 mm ID	Packed	Large Volume (LV) PTV Mode
			✓	Capillary, 0.53 mm ID	Cold On-Column	Large Volume (LV) On-Column Mode

Regardless of your sample throughput requirements, Scion can provide an automated solution to meet your needs. Four samplers are available, the CP-8410, CP-8400, the SHS-40 and the PAL Combi-xt. Each is tailored to meet a differing need and workload.

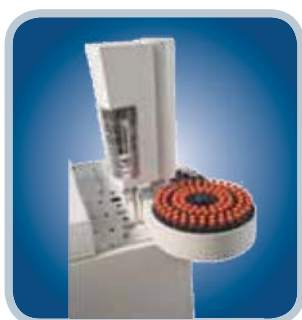

#### **CP-8400**

- High throughput
- 100 x 2ml sample capacity
- Dual/Duplicate Injection
- SPME



#### **CP-8410**

- Flexibility
- Accommodates 2, 5, 10 ml vials
- Low cost/high performance
- Ease of use



#### **SHS-40**

- Fully automated
- Easily Integrated
- Low maintenance
- Sample Loop or Press and Inject configuration



#### **PAL Combi-xt**

- High throughput
- Liquid handling capability
- SPME
- ITEX

# Scion-Certified Consumables for Your SCION GC Series

Scion GC columns span a broad range of column diameters, stationary phases, and capillary column materials: Fused Silica (FS) and Inert Steel (IS). Ideal for either routine or research type analyses. Scion GC column offerings bridge across many important applications and include a number of offerings such as:

- Standard WCOT (Wall Coated Open Tubular)
- Solid Stationary Phase PLOT (Porous Layer Open Tubular)
- Inert Steel Micro-Packed and Packed

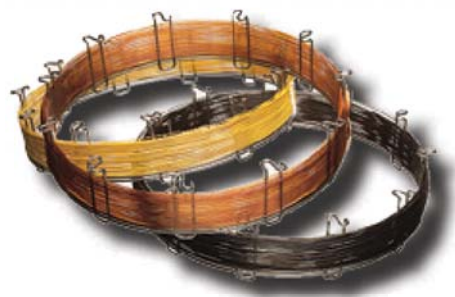

## Super Clean™ Gas Filters

Scion Gas Purification Systems have the range to satisfy your needs from individual to combination filters, from Ultra purity combined with Ultra capacity, to all in one solution kits. Innovative features designed into the product yield extensive benefits to the user.

- Ultra-high capacity for long life, less change and improved productivity
- High-purity output ensures 99.9999% Pure Gas
- “Quick connect” fittings for easy, leak-tight filter changes
- Glass internals prevent diffusion; plastic externally for safety
- Easy-to-read indicators for planned maintenance and improved up-time

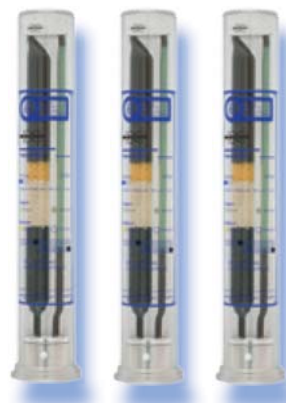

[www.ScionInstruments.com](http://www.ScionInstruments.com)

For research use only. Not for use in diagnostic procedures.

● [www.ScionInstruments.com](http://www.ScionInstruments.com)